

**MODEL 7600
HIGH SPEED
STRAIN GAGE
READOUT/CONTROLLER**

DESIGN CONCEPTS INC

**707 N. Lindenwood
Olathe, Kansas 66062**

PHONE : (913) 782-5672

FAX : (913) 782-5766

E-MAIL : info@designconceptsinc.biz



HIGH SPEED STRAIN GAGE READOUT / CONTROLLER

FEATURES

- 62.5 to 500 Samples per second (adjustable)
- mV/V adjust easily setup on front panel without external millivolt source
- Auto tare up to 50% with front panel pushbutton or remote input
- Digital filtering for stable display reading
- RS232 or RS422 outputs available
- Peak and valley detect and hold
- Excitation for up to four 350 ohm bridges
- Span programmable from 1 to 199999 counts via front panel switches or RS232/422
- Remote sensing for six wire hookup (optional)
- Analog output (optional)
- Four alarm points

The Series 7600 is a new generation user friendly, high speed, high resolution strain gage readout/controller. The 12 bit analog to digital converter has an adjustable update of 62.5 to 500 times per second and every reading is checked against four limits and the peak and valley readings. The 12 bit analog to digital converter updates 500 times per second and each reading is put into storage for the front end digital filter. The front end filter can be programmed to be a digital average of 1 to 8 conversions and the peak, valley and four limits are checked against this number. The output of the front end filter is fed into the display filter which can be programmed to take the digital average of 1 to 100 of the averaged numbers from the front end filter. The span and four limits are easily programmed via the front panel switches or RS232/422 and can be set to any number from ± 1 to ± 199999 . Auto tare of $\pm 50\%$ of span is accomplished with a front panel push button or via remote switch closure and automatically offsets the optional analog output to zero. Set up of mV/V is done from the front panel of the unit with dip switches and the unit's own display. No external millivolt source is required so the unit does not have to go back to the calibration shop. The unit is ratiometric with all calibration voltages being referenced back to the reference of the A/D chip, including the bridge excitation voltage which can drive up to four 350 ohm bridges. RS232 or RS422 options are available for easy integration into larger systems and various power supply options are available with 115VAC being standard.

SPECIFICATIONS

Accuracy: $\pm .05\%$ of reading ± 2 counts of A/D @ 25°C. Temperature coefficient 25ppm/degree Celsius.

Resolution of A/D: 12 bits

Input Impedance: 10^9 ohms.

Input Bias Current: ± 50 nA maximum ± 100 pA/°C.

NMRR: 70db

CMRR: 70db

Rollover Error: ± 3 counts of A/D

Front Panel Controls: (Located behind lens)

Span adjust switches

Tare pushbutton (optional through lens)

Decimal point selector switch (5 decimal points I.X.X.X.X)

Digital filter average set: 1 to 100 conversions

mV/V calibrate pushbutton and potentiometer

mV/V select dip switch 1.5mV/V through 3.5 mV/V.

Peak and valley reading display and reset.

Visual Indicators: 5½ digits. .56" red LED with polarity.

Outputs: Limit output: +5V at limit, 1 TTL load

ASCII RS232 compatible: (optional)

ASCII RS422 compatible: (optional)

Baud rates: 300, 600, 1200, 2400, 4800, 9600

Analog output: (optional) 0 to ± 10 VDC @ 1mA max.

Excitation output: 10VDC @ 120mA max.

Remote sensing (six-wire hookup) (optional)

Sample Rate: 62.5 to 500 per second for peak, valley, and limits.

Input Filter: 2.5 KHz single pole passive filter. Digital filter for display can be set to be an average of last 1 to 100 conversions. Front end filter can be set to be a digital average of last 1 to 8 conversions.

Power: 115VAC 50-400hz 8 watts maximum.

(optional) 230VAC 50-400hz 8 watts maximum.

(optional) 10-30VDC 500 mA maximum.

(optional) 5VDC 600mA maximum.

Remote Inputs:

Tare.

Display peak reading.

Display valley reading.

Reset peak/valley reading.

Remove tare.

Operating Temperature Range: Zero to fifty degrees Celsius.

I/O Method: Input power via screw terminals. 2 subminiature "D" connectors for strain gage hookup and RS232 output. Mating "D" connector for strain gage hookup is supplied with unit.

Case Size: "B" SEE QUICK REFERENCE CHART

OPTIONS

- | | | |
|------|--|--|
| • 01 | ASCII RS232 compatible output | \$65.00 |
| • 02 | ASCII RS422 compatible output | \$65.00 |
| • 03 | Six-wire hookup for strain gage remote sensing | \$50.00 |
| • 05 | 5VDC input power. 600mA max. | \$70.00 |
| • 09 | Analog output 0 to ± 10 VDC @ 1mA maximum. | \$15.00 |
| • 20 | Tare button brought out through front panel | \$ 5.00 |
| • 22 | 230VAC, 50-400hz power | \$10.00 |
| • 23 | Green LED display | \$50.00 |
| • 24 | 10-30VDC input power. 500mA maximum | \$95.00 |
| • 25 | Special legends and/or logo (Special artwork to be supplied by customer) | One time charge \$55.00
Plus per lens \$ 5.00 |
| • 26 | No logo | \$ 3.00 |
| • 28 | Blank lens | \$ 3.00 |
| • 29 | I/O subminiature "D" connector for RS232/RS422 and reset for peak/valley detect. | \$15.00 |
| • 30 | "MILLIVOLTS" legend | \$ 5.00 |
| • 31 | "D.C. VOLTS" legend | \$ 5.00 |
| • 37 | "D.C. AMPERES" legend | \$ 5.00 |
| • 38 | "PSIG" legend | \$ 5.00 |
| • 39 | "PSIA" legend | \$ 5.00 |
| • 40 | "PSI" legend | \$ 5.00 |
| • 41 | "POUNDS" legend | \$ 5.00 |
| • 50 | Sunlight readable .6" LED display. No polarity available. | \$35.00 |

SECTION 1

General

The Series 7600 is a general purpose microprocessor based strain gage readout with 4096 count resolution and selectable digital filtering with up to 1.6 seconds of averaging for the display and two millisecond response time for the four limits, peak detect and valley detect. It features display of peak reading, display of valley reading, sensitivity selection, display of sensitivity selection, span selection, display of span selection, decimal point selection, auto tare, display of tare, zero adjust, and remote TTL inputs on some functions. Optional outputs and inputs include RS232C, RS422, baud rate selection, and analog output. All contained in a compact aluminum panel mount case with bright LED readouts. See attached drawings for electrical specifications, switch locations, and mechanical dimensions

Analog input:

The analog input is a high impedance differential amplifier with gain selection from 1.5 to 3.5 millivolts per volt, which is selected with 4 dip switches and a potentiometer located behind the front panel. Analog to digital conversion is done with a highly accurate successive approximation A/D converter chip.

MV/V switch:

The millivolt per volt switch allows displaying of the input MV/V sensitivity selection. Sensitivity is adjusted while this switch is pressed. Both MV/V and sensitivity dip switches are located behind the front panel.

Tare switch:

The tare switch is a multifunction switch, each function depends on how long the switch is pressed. When the tare switch is pressed the display will show the stored tare value, after about 2 seconds the display will flash, if the switch is released actual displaying will resume. If the switch is not released, a new tare value will be entered, the display will now show the new tare value. If the switch is released actual displaying will resume, The new tare value is stored in a non-volatile memory and is retained during power failure.

Zero tare switch:

The zero tare switch makes the tare value zero.

SECTION 2

Connector identification: For connector diagrams see section 7.

AC POWER INPUT (J3):

Screw terminal strip.

Looking Left to Right from rear, top up.

Left: Strain gage cable shield or earth ground.

Center left: AC power input

Center right: AC power input

Right: Strain gage cable shield or earth ground.

Power requirements: 110 volts AC, 50-400 Hz., 8 watts max.

DC POWER INPUT (J3):

Left: Positive 10-30VDC power input.

Center left: No connection.

Center right: No connection.

Right: 10-30VDC power return.

Strain Gage Input (J2):

Connector type: DB-9S

Excitation voltage: 10 volts DC at 100 milliamps max.

Pin 1 + Signal
Pin 2 - Signal
Pin 3 - Excitation/ Optional analog output return.
Pin 4 (-) Sense / 6 wire strain gage only.
Pin 5 No connection / Optional analog output.
Pin 6 + Excitation / Optional +15 Volts @ 50 milliamps.
Pin 7 (+) Sense / 6 wire strain gage only.
Pin 8 No connection / Optional -15 Volts @ 50 milliamps.
Pin 9 Strain gage cable shield

Data Outputs (J1)

Connector type: DB-25S

Pin 1 Logic Ground
Pin 2 Transmit Data RS232C - Transmit Data High RS422
Pin 3 Receive Data RS232C - Receive Data Low RS422
Pin 4 Ready to Send RS232C - Ready to Send High RS422
Pin 5 Clear to Send RS232C - Clear to Send Low RS422
Pin 6 Logic Ground
Pin 7 Signal Ground RS232C
Pin 8 Remote Input #1 Tare
Pin 9 Remote Input #2 Zero Tare

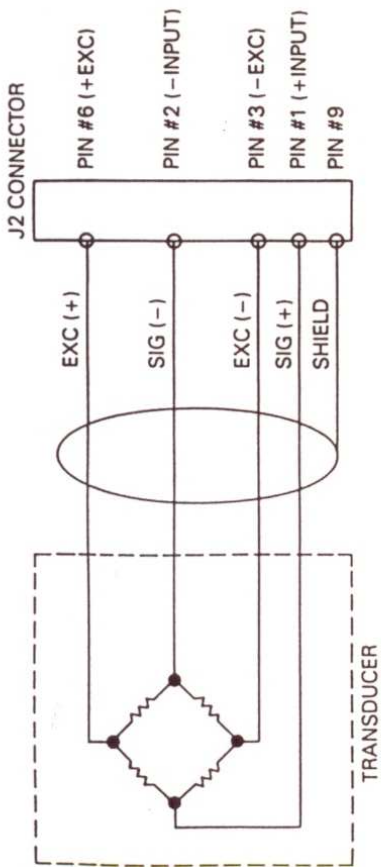

7600 USING INTERNAL 10 VDC EXCITATION

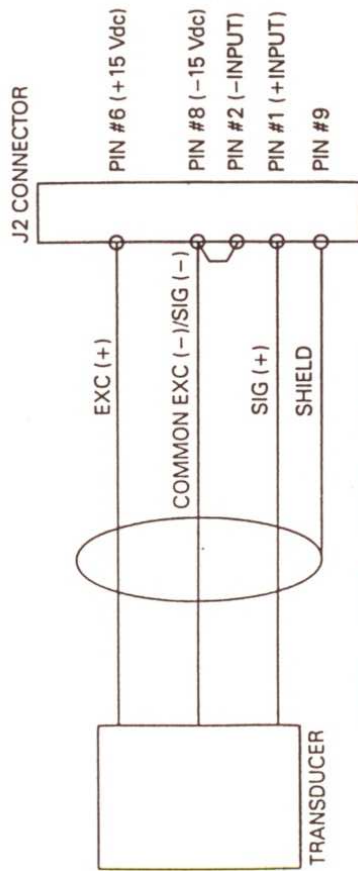

7710, 7720, 7730, & 7770
USING INTERNAL 30 VDC SUPPLY
(If using 15 Vdc power, tie pin #3 to Common
not pin #8)

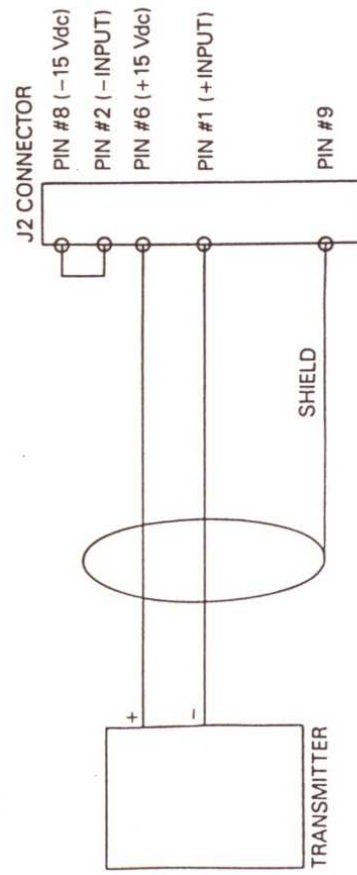

7750 USING INTERNAL 30 VDC EXCITATION
(If using internal 15 Vdc supply, tie
pin #2 to pin #3, not pin #8)

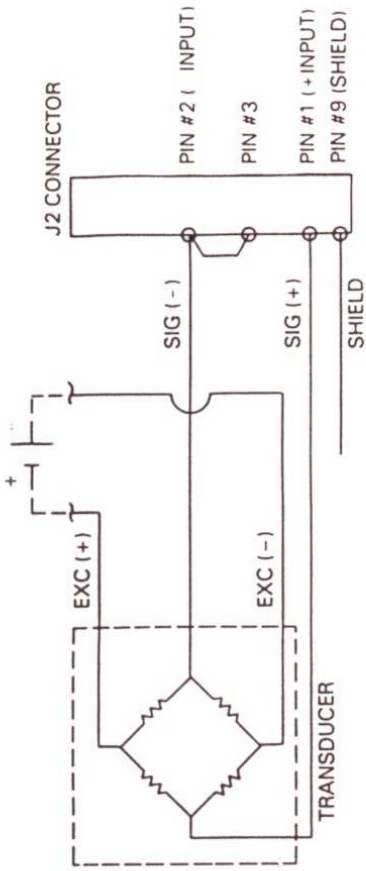

7760 WITH EXTERNAL POWER SUPPLY

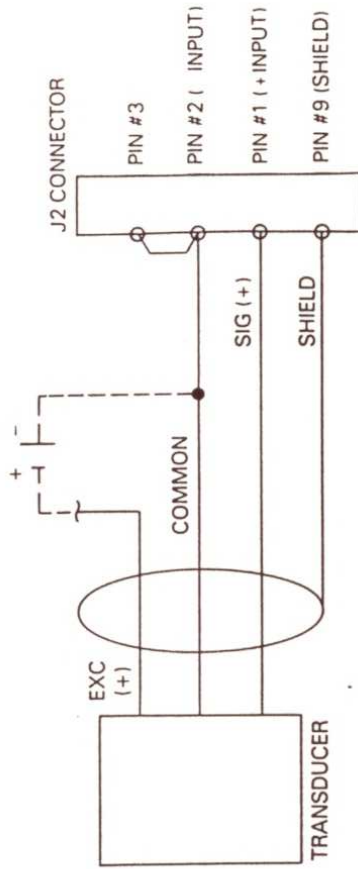

7710, 7720, 7730, & 7770
WITH EXTERNAL POWER SUPPLY

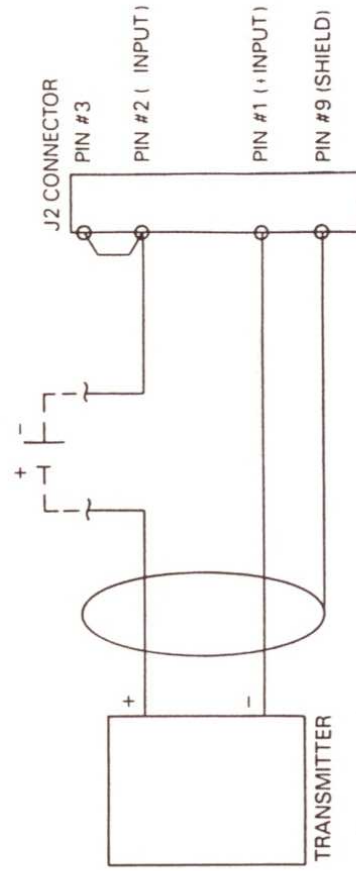

7750 WITH EXTERNAL POWER SUPPLY

Pin 10 Remote Input #6 Valley Reading Reset
Pin 11 Remote Input #3 Peak Reading
Pin 12 Limit 4 output
Pin 13 Remote Input #4 Peak Reading Reset
Pin 14 Transmit Data Low RS422
Pin 15 Receive Data High RS422
Pin 16 Request to Send Low RS422
Pin 17 Clear to Send High RS422
Pin 18 Spare input
Pin 19 Spare output
Pin 20 Limit 1 output
Pin 21 Limit 3 output
Pin 22 Logic Ground
Pin 23 +5VDC
Pin 24 Remote Input #5 Valley Reading
Pin 25 Limit 2 output

SECTION 3

PROGRAMMING LIMITS, DIGITAL FILTER, SPAN, DECIMAL POINT, AND SERIAL INTERFACE OPTIONS:

All parameters are programmed after putting the unit into the set up mode which is accomplished by first toggling and holding the MV/V-setup switch to the left, and then depressing the function switch. The display will now show ".1." which indicates the unit is ready to set up limit number one.

3.1 LIMIT PROGRAMMING:

After getting the unit into the setup mode the number ".1." will show for approximately two seconds and then the display will show the number that is presently stored in memory as limit number one. The ones unit digit on the limit will be flashing which indicates it is the digit ready to be programmed. To increment this digit momentarily depress the tare button and the digit will increment once each time the tare button is depressed. After programming the digit depress the zero tare button and the next digit to the left will flash indicating it is ready to be programmed. Program this digit in the same manner as the first and then proceed to the remainder of the digits. After programming the 5 digits press zero tare button. The sixth digit will display "1" or blank: to change, press tare. After sixth digit, press zero tare. Unit will display (- sign or blank; to change, press tare.

After programming limit number 1 momentarily depress the function switch and the number ".2." will come up on the display indicating limit number 2 is ready to be programmed. After about two seconds ".2." will disappear and the number stored in memory as limit number 2 will be displayed with one digit flashing. Program

limit number 2 in the same fashion as limit number 1.

Limit number 3 and 4 are accessed and set up the same way as limit number 1 and 2.

To exit the set up mode at any time depress the function switch and hold until the display goes blank (about two seconds).

3.2 PEAK THRESHOLD SETUP:

After the 4 limits are programmed the peak threshold which is a limit in which the peak must exceed before the peak comparisons will be performed and the display will start showing the peak number. The peak threshold setup will be indicated by the number ".0." showing on the display for about two seconds, and then the peak threshold numbers. Number selection is done the same was as the limits.

3.3 DIGITAL FILTER SETUP:

After the limits are programmed momentarily depress the function switch and the unit will display a one digit number which is the number of A/D conversions that are averaged for the limits, peak and valley comparisons. The time of one A/D conversion is two milliseconds so if the filter number is set at 01 the comparisons will be every two milliseconds if the filter number is set at 02 then the comparison will be the average of two conversion or four milliseconds. This number can be incremented up to a maximum of 08 using the tare switch. When making a change on the digital filter the limits and peak threshold must be re checked. The sampling rate for max, min, and alarms $(2\text{ms to } 16\text{ms}/62.5 \text{ to } 500\text{hz}) = \text{A/D conversion}(2\text{ms/sample}) \times \text{digital filter}(\text{no of samples } 1 \text{ to } 8)$.

3.4 DISPLAY DIGITAL FILTER SETUP:

After the digital filter is programmed momentarily depress the function switch and the display will display a three digit number which is the number of A/D conversions x DIGITAL FILTER NUMBER that are averaged for the display. The time of one A/D conversion is two millisecond so if the digital filter number is set at 02 and the display filter is set at 10 the display will be the average of 20 conversions and updated every 40 milliseconds. This number can be incremented up to a maximum of 100 using the tare switch or down using the zero tare switch. This setting does not affect the response time of the peak detect, valley detect, or the four limit set point detect times which are fixed by the digital filter number. The display update rate $(2 \text{ to } 1600\text{ms}/62.5 \text{ to } 500\text{hz}) = \text{A/D conversion}(2\text{ms/sample}) \times \text{digital filter}(1 \text{ to } 8) \times \text{display filter}(1 \text{ to } 100)$.

3.5 SPAN SET UP:

After setting up digital filter momentarily depress the function switch and the display will show the current span selected with a digit flashing which indicates that digit is ready to be programmed. Increment this digit to the number desired by depressing the tare switch. The digit will increment once each time the tare switch is depressed. After programming that digit depress the zero tare switch and the next digit to the left will flash indicating that digit is ready to program. Increment this digit using the tare switch then proceed to the remainder of the digits which are programmed in the same manner.

3.6 DECIMAL POINT SELECTION:

After setting the span the next selection is decimal point location. The decimal point may be selected to appear in any position or off. To move the decimal point, press the tare button and the decimal point will rotate one position to the left. This setting has no bearing on the scaling or the reading. To exit the set up mode depress the function switch until the display blanks.

3.7 Optional RS232/RS422 setup: After setting the decimal point momentarily depress the function switch and if either of these options are installed the display will show the current unit address programmed which may be incremented with the tare switch and decremented with the zero tare switch. Momentarily depress the function switch and the unit will display the baud rate presently programmed which may be incremented using the tare button. If the function switch is again depressed the unit will go back to the set up for the limits. To exit the set up mode depress the function switch until the display blanks (approximately two seconds). All setup parameters are stored in nonvolatile memory and will be maintained during loss of power.

SECTION 4

4.1 MV/V select:

The MV/V selection dip switch allows sensitivity adjustments of the A/D. A combination of the four switches will give 16 approximate ranges which may be fine adjusted by the MV/V calibration pot. In the table below Zeros (0) are Down or On, and Ones (1) are Up or Off. Note that MV/V is output at full scale, and the MV/V input is MV at full scale-MV at zero.

1	2	3	4	MV/V	MV input	1	2	3	4	MV/V	MV input
0	0	0	0	1.490	14.90	0	0	0	1	2.140	21.40
1	0	0	0	1.550	15.50	1	0	0	1	2.260	22.60

0 1 0 0	1.610	16.10	0 1 0 1	2.400	24.00
1 1 0 0	1.680	16.80	1 1 0 1	2.560	25.60
0 0 1 0	1.750	17.50	0 0 1 1	2.740	27.40
1 0 1 0	1.840	18.40	1 0 1 1	2.940	29.40
0 1 1 0	1.930	19.30	0 1 1 1	3.180	31.80
1 1 1 0	2.030	20.30	1 1 1 1	3.460	34.60

To achieve any MV/V or millivolt input between the values shown above, proceed to calibration procedure page 10.

4.2 Peak Reading:

Displaying of the peak reading is accomplished by pressing and holding the function switch (the display will then blank) and then pressing the tare switch, the peak reading (highest positive or lowest negative) will be displayed for approximately 2 seconds, the display will then start to flash, if the tare switch is not released. the peak reading will be reset to the current actual reading. When the tare switch is released the display will blank until the function switch is released. The peak reading is compared after each conversion, approximately two millisecond.

4.3 Valley Reading:

Display of the Valley Reading is accomplished by pressing and holding the function switch (the display will then blank) and then pressing the zero tare switch, the valley reading (highest negative or lowest positive) will be displayed for approximately 2 seconds, the display will then start to flash, if the zero tare check switch is not released the valley reading will be reset to the current actual reading. When the zero tare switch is released the display will blank until the function switch is released. The valley reading is compared after each conversion, approximately two millisecond.

4.4 Remote Inputs:

Located on connector J1 are six remote inputs which can control the display. These are Low Power TTL compatible inputs or switch closures to logic ground, 0 volts minimum to 5 volts maximum and must be present a minimum of 20 milliseconds,

Input #1 Tare: Remote tare when held low will set a new tare value, same as pressing the tare switch except does not display the tare value.

Input #2 Zero Tare: Remote zero tare when held low will zero the tare value, same as pressing the zero tare switch except does not display the tare value.

Input #3 Peak Reading: Remote peak reading when held low will display the current peak reading. May be tied low (logic ground) for continuous peak reading display. Once the unit has

detected a peak, ie, the input drops, the display will lock up and display that number until it is reset. When in the Peak Reading mode all limits will latch up when the limit is reached. In the normal display mode the limit will track the display.

Input #4 Peak Reading Reset: Remote peak reading reset when held low will reset the peak reading to the current actual reading.

Input #5 Valley Reading: Remote valley reading when held low will display the current valley reading. May be tied low (logic ground) for continuous valley reading display. Once the unit has detected a valley the display will lock up and display that number until the unit is reset.

Input #6 Valley Reading Reset: Remote valley reading reset when held low will reset the valley reading to the current actual reading.

SECTION 5

Analog Output:

If the analog output option is installed the output will track the normal display reading with the tare subtracted. The output will swing 0 to +/-10 volts at the full scale reading of 4095 counts, which is 2.44 millivolts per count of A/D. The output will drive a 10 K ohm load.

SECTION 6

Serial Input/Output:

If the serial input/output option is installed it allows the Series 7600 to communicate with a remote computer or terminal. Two standard signal levels are available, RS232C or RS422. Almost all functions available from the front switches can be duplicated by the host computer. Listed below are all commands, with a full description following.

- AD Address Disable
- AE Address Enable
- AT Auto Tare
- AU Abort Update
- CU Continuous Update
- RD Read Display
- RP Read Peak
- RS Read Span
- RT Read Tare

RV Read Valley
S1 Set Limit 1
S2 Set Limit 2
S3 Set Limit 3
S4 Set Limit 4
SP Set Peak
SV Set Valley
V1 Verify Limit 1
V2 Verify Limit 2
V3 Verify Limit 3
V4 Verify Limit 4
ZT Zero Tare

The serial data is transmitted as ASCII characters, using the selected baud rate, each word or character is made up of eight data bits, one stop bit and no parity bit. The format of data transmitted depends on the command, and is expected to be transmitted or receive left most character first and terminated with a carriage return (c.r.) when an additional number is required leading zeros or place holders may be omitted. Plus sign is optional but must proceed the number. Received numbers will have the decimal point ignored. Transmitted numbers will have a decimal point to conform to the display format. In the command descriptions below the command string will be shown within brackets ([]), the sign if required will be shown as a lower case (s), and the number as upper case (X). Each command will be executed when received and only once except for display data which may be enabled to continuously update until disabled.

Address Disable: [ADXXc.r],[ADc.r.]

Address disable is a command used with the RS422 serial interface when several units will be in parallel on the serial buss, or with RS232C, to disable the unit. This command allows the unit specified by the address number XX to be turned off or disabled. The address must be in the range of 1 to 99. If no number is supplied all units on the serial buss will be turned off or disabled. If the unit is disable by unit address number the unit will respond with [BYEc.r.].

Address Enable: [AEXXc.r.]

Address enable is a command used with the RS422 serial interface when several units will be in parallel on the serial buss, or with RS232C, to enable the unit. This command allows the unit specified by the address number XX to be turned on or enabled, the address must be in the range of 1 to 99. When enable the unit will respond with [HELLOc.r.].

Abort Update: [AUC.r.]

Abort update is a command that will turn off the unit from continuous update of display data. The unit will respond with [OKc.r.].

Auto Tare: [ATc.r]

Auto tare is a command which will tare the unit. See tare switch description. The unit will respond with [OKc.r.]. Note: See ZT command.

Continuous Update: [CUc.r.]

Continuous update is a command that will put the unit in a mode where it will send the last requested display data continuously until disabled by either an AU or AD command. An example would be [RVc.r.][CUc.r.] where the unit will now send the valley reading after each conversion. The unit will respond with [OKc.r.].

Read Display: [RDc.r.]

Read display is a command that will return the normal display reading, (display mode when not in Peak, Valley, Span check, ect.) The returned data format will be [sXXX.XXXc.r.] where (s) is the sign if minus, (X) is the number, and (.) is the decimal point if in the display.

Read Peak: [RPc.r.]

Read peak is a command that will return the peak display reading. The returned data format will be [sXXX.XXXc.r.] where (s) is the sign if minus, (x) is the number, and (.) is the decimal point is in the display.

Read Span: [RSc.r.]

Read span is a command that will return the current span selection. See Span Switch. The return data format will be [XX.XXXc.r.] where (X) is the number and (.) is the decimal point if in the display.

Read Tare: [RTc.r.]

Read tare is a command that will return the current tare value. The return data format will be [sXXX.XXXc.r.] where (s) is the sign if minus, (X) is the number, and (.) is the decimal point if in the display.

Read Valley: [RVc.r.]

Read Valley is a command that will return the valley display reading. The returned data format will be [sXXX.XXXc.r.] where (s) is the sign if minus, (X) is the number, and (.) is the decimal point if in the display.

Set Limit: [S#XXXXXXc.r.]

Set limit is a command that will set the value of one of the four limits. "S" is the command. "#" is the limit number from 1 to 4. "X" is the numeric value from 1 to 19999. X may be preceded by a "+" or a "-". The + is optional.

Set Peak: [SPc.r.]

Set peak is a command that will set the current peak value to the current actual display reading or reset the peak to the current lowest reading. The unit will respond with [OKc.r.].

Set Valley: [SVc.r.]

Set valley is a command that will set the current valley value to the current actual display reading or reset the valley to current highest reading. The unit will respond with [OKc.r.].

Verify Count: [VXc.r.]

Reads the limit back. V is the command. "X" is the limit number.

Zero Tare: [ZTc.r.]

Zero tare is a command that will set the current tare value to zero (0) and will store the new value in the non-volatile memory. See Tare Switch. The unit will respond with [OKc.r.].

Serial Interface connections:

TXD (Transmit Data):

Transmit data is an output signal where the unit will transmit its serial data.

RXD (Receive Data):

Receive data is an input signal where the unit will receive its serial data.

RTS (Ready To Send):

Ready to send is an output signal where the unit requests permission from the host to send data, or the unit is ready to send data.

CLS (Clear To Send):

Clear to send is an input signal which must be high to allow the unit to send data. If not used it must be tied high.

SECTION 7

Calibration procedure (Allow 20 min warm up time)

1. Depress zero tare switch.
2. Apply zero MV across signal (+) and (-).
3. Adjust zero calibrate to zero display.
4. Unplug connection J2.
5. Select MV/V range by pressing the appropriate switches.
6. Calibrate MV/V by pressing the MV/V switch and adjusting the MV/V pot to sensitivity of load cell (strain gage). The display will show the three places to the right of the decimal point and the least significant digit may change in steps greater than one.
7. Select span by going to the set up mode outlined on page two.
8. Reconnect J2.
9. Depress the tare button until the tare value appears on display then release the tare button.

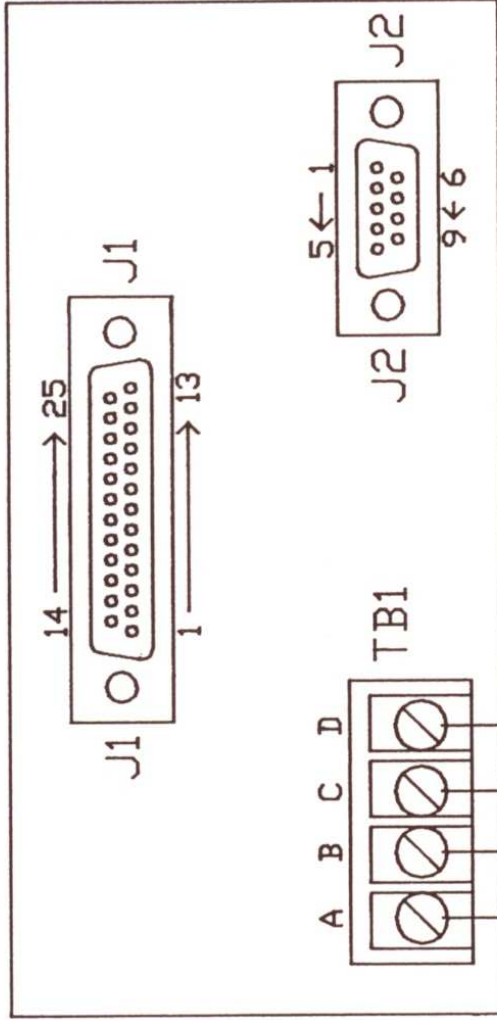

+5VDC IN FOR OPT.-05
 +10-30VDC IN FOR OPT.-24

EARTH GROUND
 POWER RETURN FOR
 OPT.-05 OR -24

AC POWER
 115VAC STANDARD
 220VAC FOR OPT.-22

TITLE

SERIES 7600
 CONNECTOR
 LOCATOR

DRAWING NUMBER

89-0003-10

DCI Inc.

OLATHE, KANSAS

DRAWN MATT DEMAREE

APPROVED *J. H. Heman*

DATE NOV 5, 1987

ECD:

CHANGED BY:

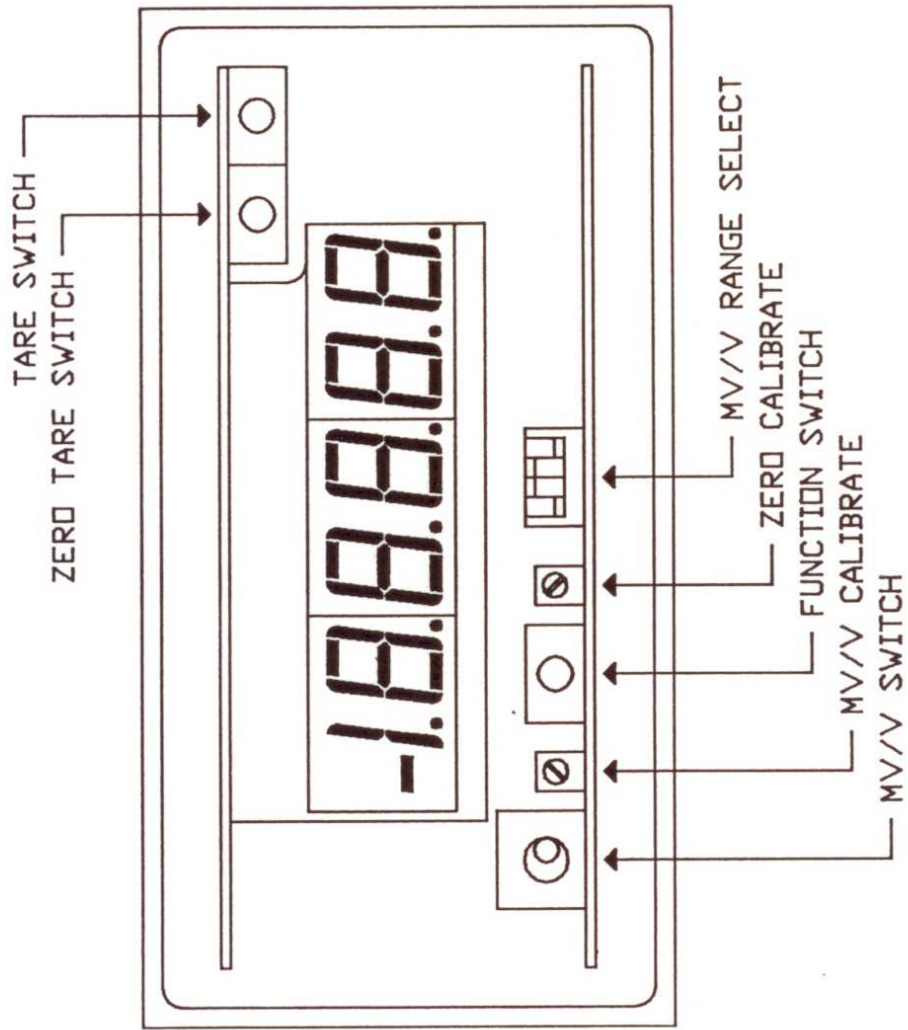

TITLE	DCI Inc.		
	OLATHE, KANSAS		
DRAWING NUMBER	DRAWN MATT DEMAREE		
	APPROVED <i>J. M. M...</i>		
DRAWING NUMBER	DATE NOV 5, 1987		
	ECC:		
DRAWING NUMBER		CHANGED BY:	
89-0003-00			

SERIES 7600
 SETUP & ADJUST.
 PARTS LOCATOR

DCI Inc.
 OLATHE, KANSAS
 DRAWN MATT DEMAREE
 APPROVED *[Signature]*
 DATE NOV 5, 1987
 ECO: 03-0002-0A
 CHANGED BY: MD

PC BOARD P/N 93-7600-1C
SERIES 7600
AC POWER &
ANALOG FRONT END
 DRAWING NUMBER
84-0040-00

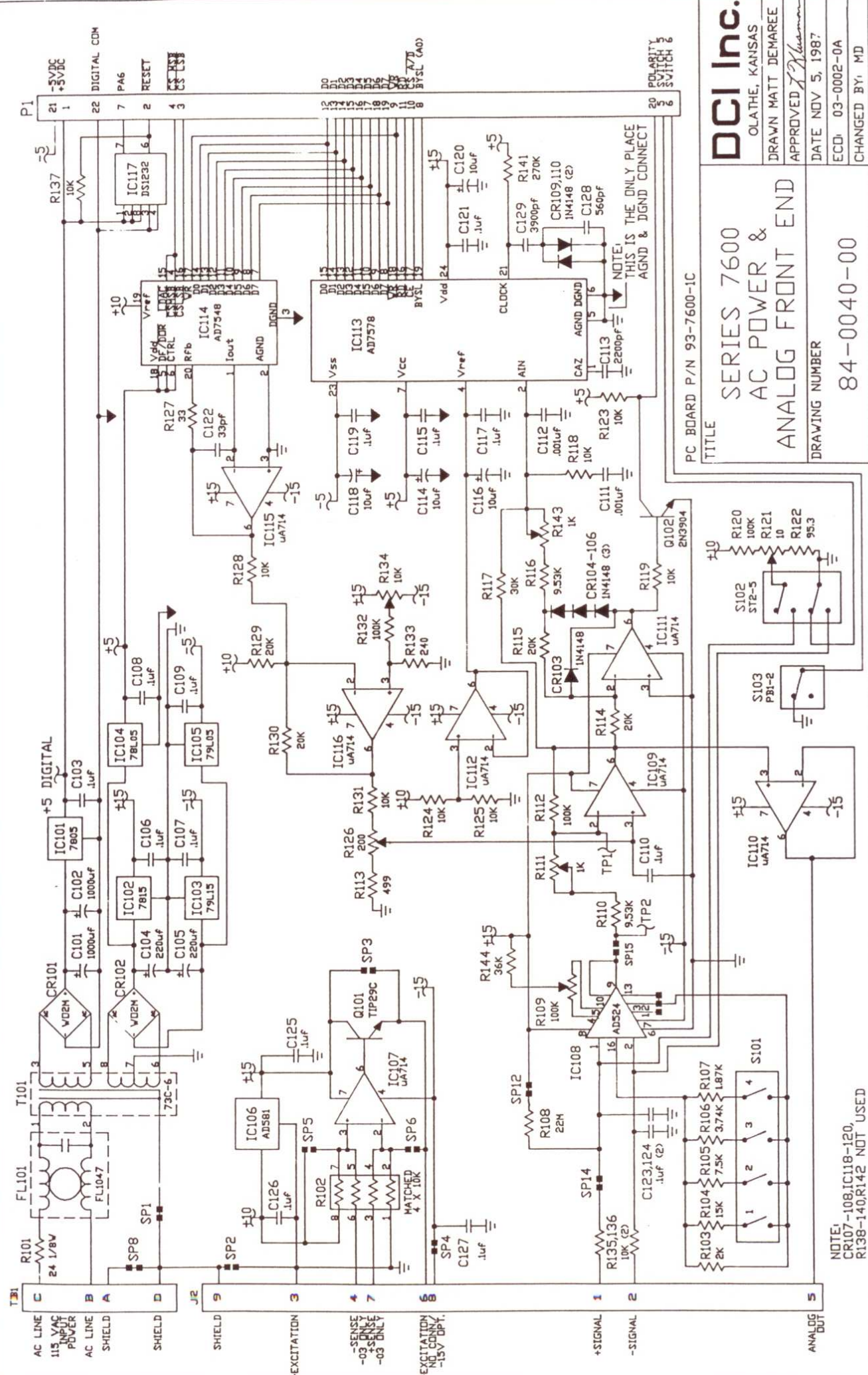

NOTE:
 CR107-108, IC118-120,
 R138-140, R142 NOT USED

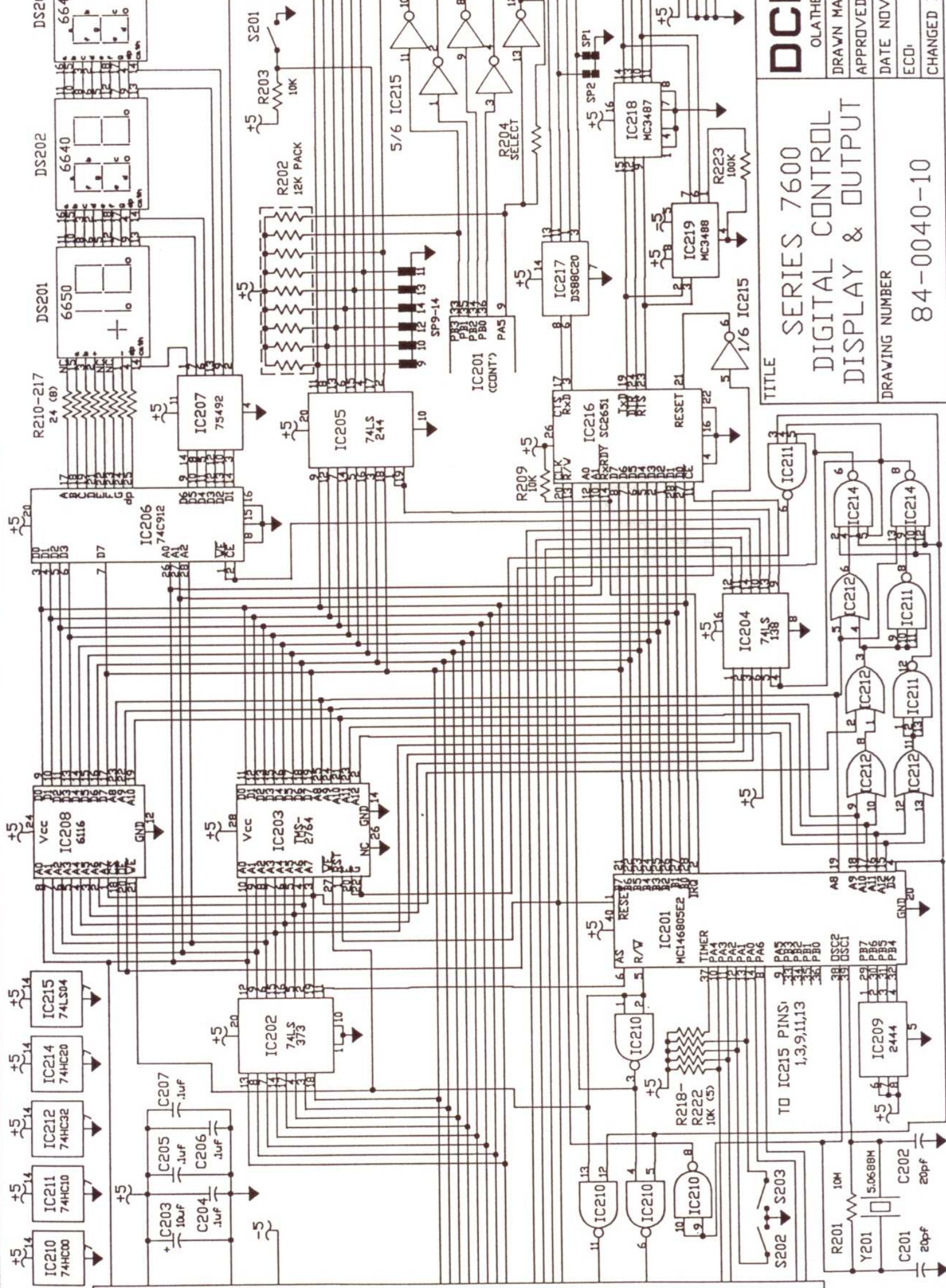

DC	OLATHI
	DRAWN MA
APPROVED	
DATE NOV	ECD
CHANGED	
TITLE	
SERIES 7600	
DIGITAL CONTROL	
DISPLAY & OUTPUT	
DRAWING NUMBER	
84-0040-10	

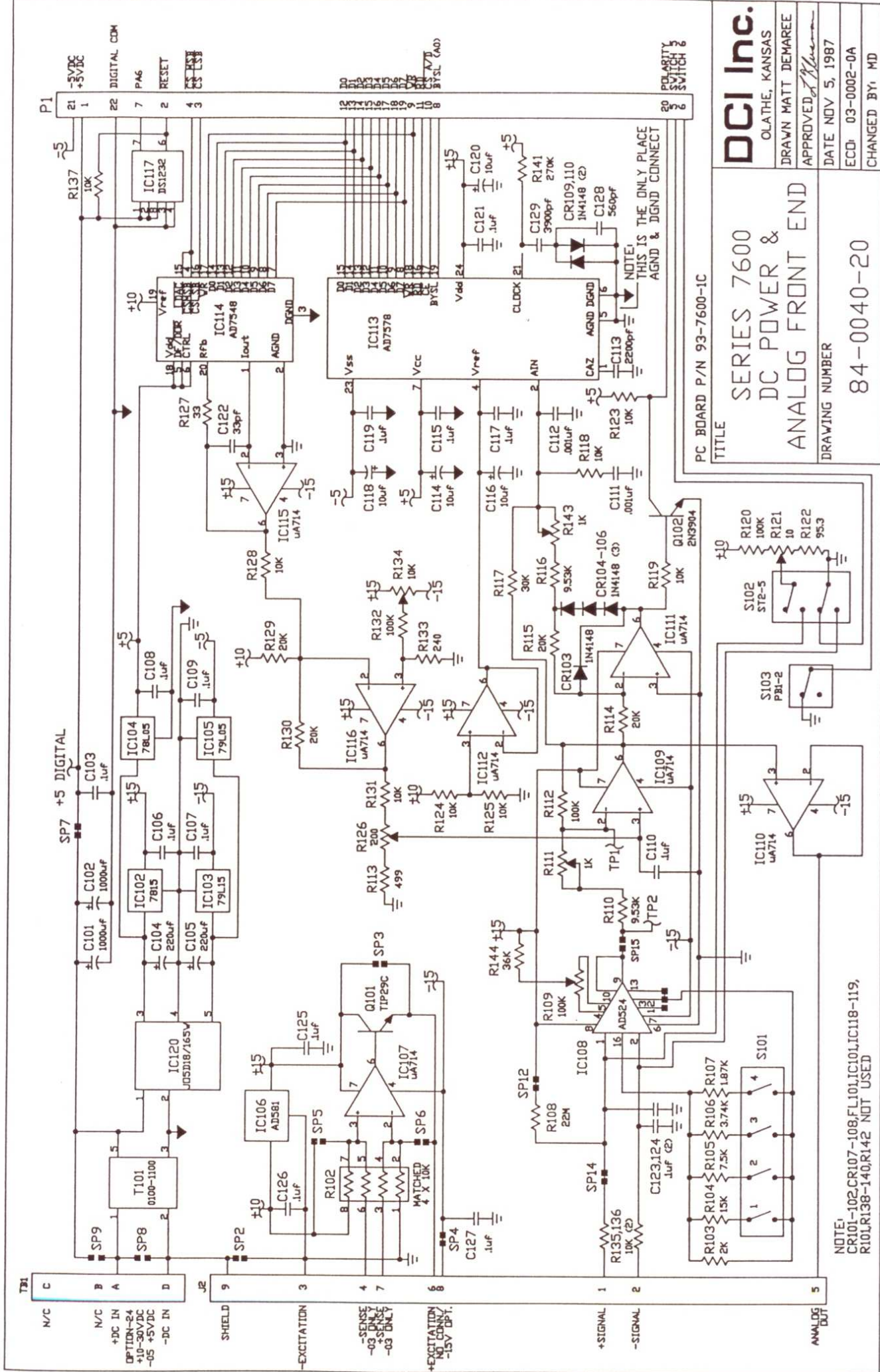

DCI Inc.
 OLATHE, KANSAS
 DRAWN MATT DEMAREE
 APPROVED: *[Signature]*
 DATE NOV 5, 1987
 ECO: 03-0002-0A
 CHANGED BY: MD

SERIES 7600
DC POWER &
ANALOG FRONT END
 DRAWING NUMBER
84-0040-20

PC BOARD P/N 93-7600-1C
 TITLE
 THIS IS THE ONLY PLACE
 AGND & DGND CONNECT

NOTE:
 CR101-102, CR107-108, FL101, IC101, IC118-119,
 R101, R138-140, R142 NOT USED

SECTION 10

SPECIFICATIONS

ACCURACY:	$\pm 0.05\%$ of reading ± 2 counts of A/D at 25 degrees C
TEMPERATURE COEFFICIENT:	25 ppm/degree C
RESOLUTION OF A/D:	12 bits
INPUT IMPEDANCE:	1000Mohm
INPUT BIAS CURRENT:	± 50 NA
NORMAL MODE REJECTION:	70dB
COMMON MODE REJECTION:	70dB
ROLLOVER ERROR:	± 3 counts of A/D
SAMPLE RATE:	Adjustable from 62.5 to 500 samples per second for min., max., and limits.
DISPLAY AVERAGING:	Adjustable from 1 to 100 samples
I/O METHOD:	Two subminiature "D" connectors supplied for strain gage hookup RS232/RS422 interface, alarms, remote min./max. display and reset, remote tare and reset.
OUTPUTS:	4 high alarms (5VDC at 24mA) no deadband.
DISPLAY:	5 1/2 digits .56" red LED with polarity.
POWER:	115VAC 50-400Hz, 8 watts maximum. Input power via screw terminals.
INPUT FILTER:	2.5 KHz single pole passive filter.
OPERATING TEMPERATURE:	0 to 50 degrees C
CONSTRUCTION:	All aluminum case
DIMENSIONS:	2.7"H x 5.18"W x 6.75"d; 2.45" X 5.06"W cutout

MOUNTING

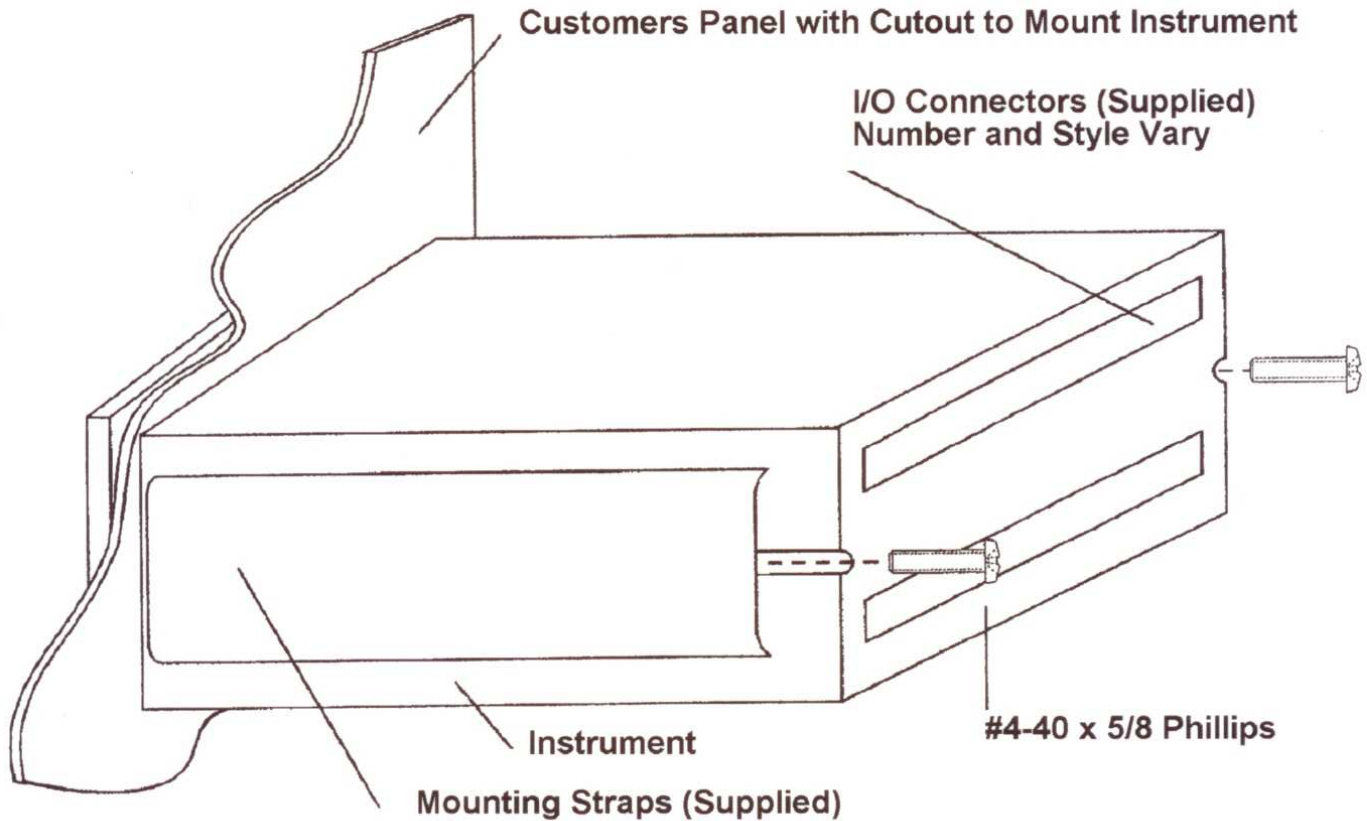

Design Concepts, Inc.

PO Box 2877

707 N. Lindenwood

Olathe, KS 66062

Phone: 913-782-5672

Fax: 913-782-5766

Web: <http://www.designconceptsinc.biz>

WARRANTY

THE FOLLOWING WARRANTY IS IN LIEU OF ALL OTHER WARRANTIES, EXPRESSED, IMPLIED OR STATUTORY, INCLUDING BUT NOT LIMITED TO ANY IMPLIED WARRANTY OF MERCHANTABILITY OR FITNESS FOR A PARTICULAR PURPOSE.

All new products sold by Design Concepts Inc. are warranted against defects in materials and workmanship for one (1) year from the date of the original shipment. During the warranty period, Design Concepts Inc. will repair or, at its option, replace without charge any Design Concepts Inc. product stated above, is limited to the repaired portion and is valid for ninety (90) days from the date of its reshipment. These warranties do not apply if the product has been damaged by accident, misuse, or modification in the absence of authorization from Design Concepts Inc. Design Concepts Inc. will not be responsible or liable for contingent, incidental, secondary or consequential costs of damages.